

LOHAS

AUSTRALIA

ROOF TILE COLLECTION
MODERN
SLATE ROOF TILE
SPEC GUIDE

LOHASAU.COM

technical drawings

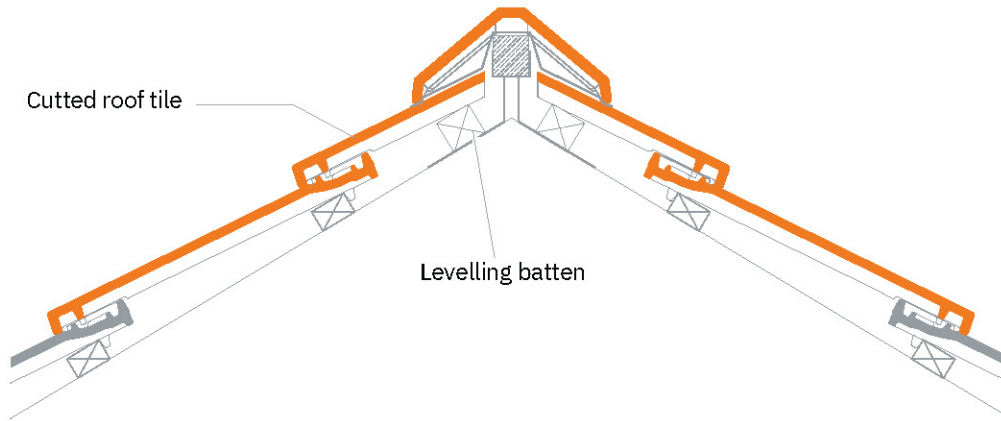
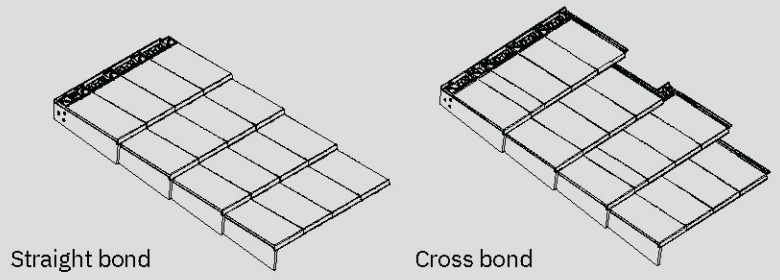

1

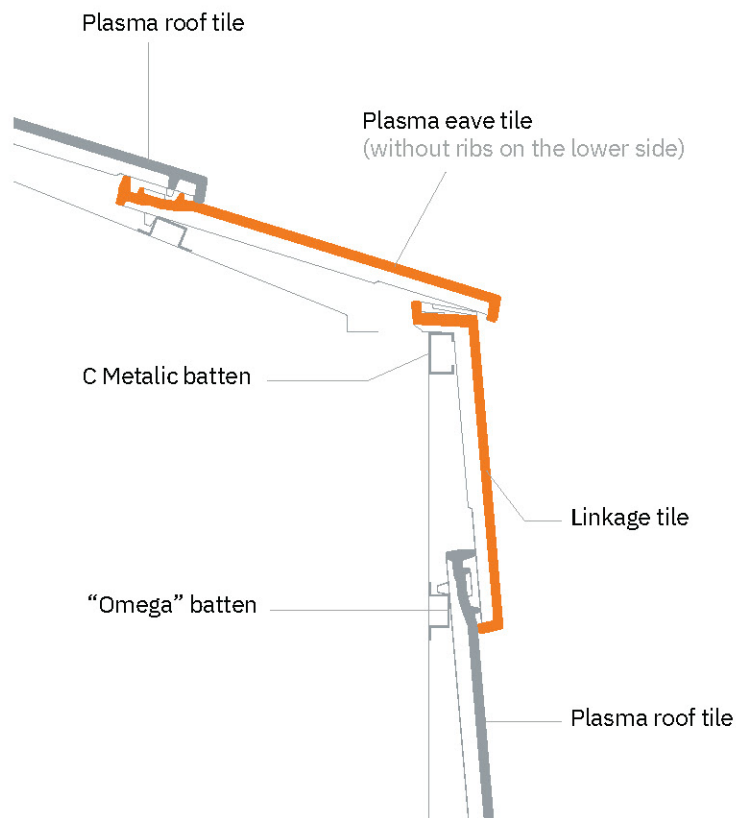

2

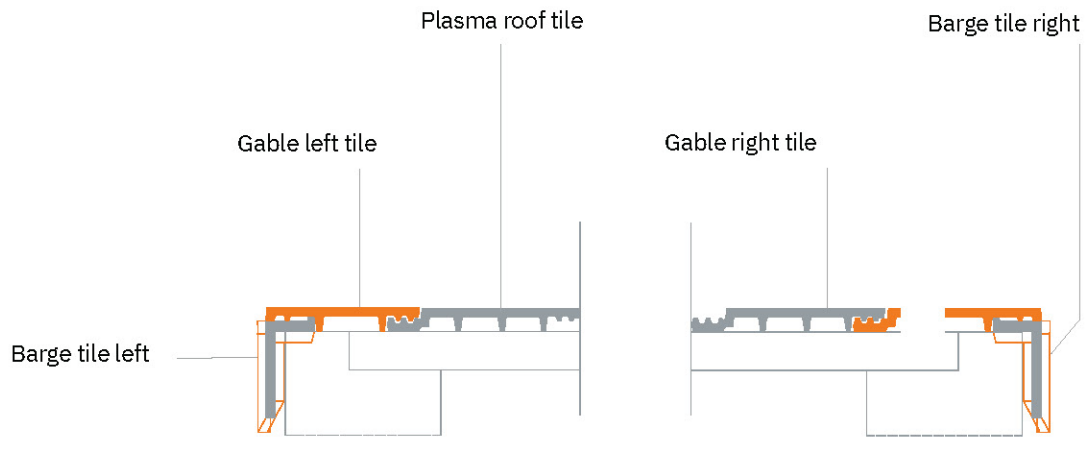

3

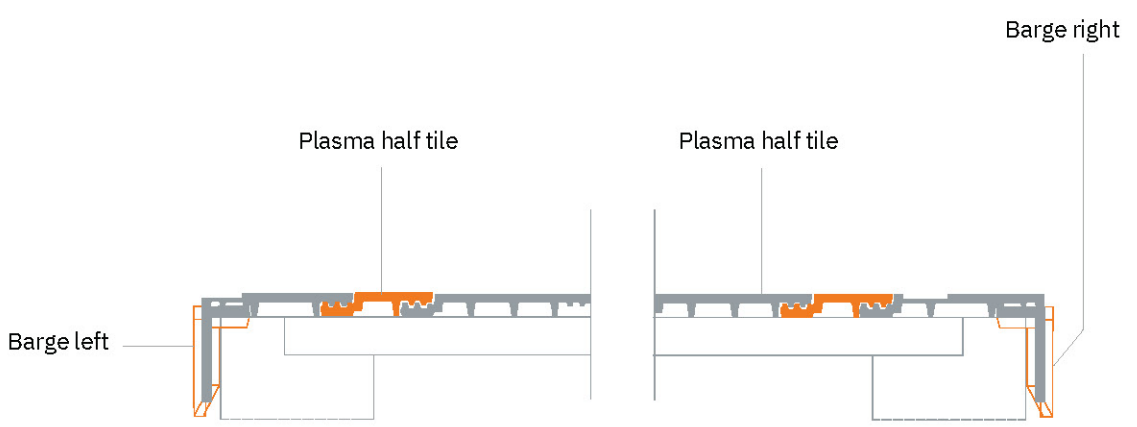

4

Plasma Technical Drawing Detail

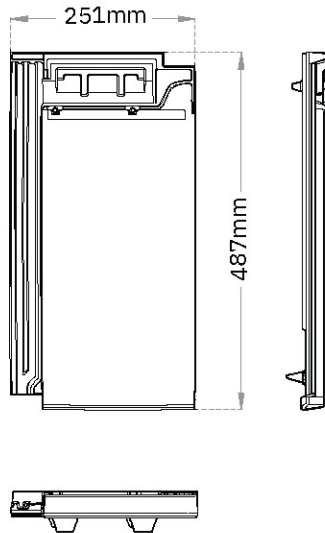

1. Transversal and longitudinal views

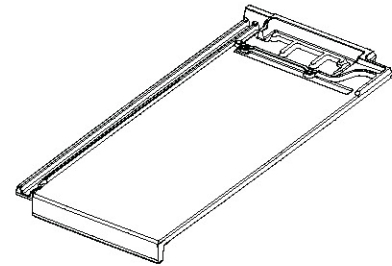

2. Isometric view

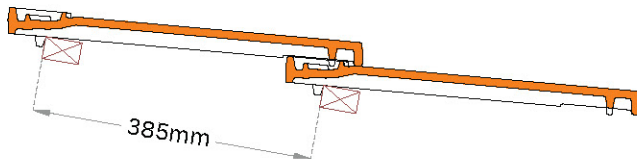

3. Average gauge length

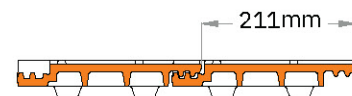

4. Coverage width of 1 Plasma roof tile

Notes:

The presented measures are approximate values in “mm”. Please consult LOHAS technical department to clarify any doubt. We strongly advise not using PVC batten due to its flexibility and way of attachment to the structure (often using nails or bolts with a significant “head”) that may interfere with the proper support of the PLASMA tile.

It is not advisable to fix Plasma roof tile using nails, however, opting for this method the tip of the nail should be adapted to prevent cracking or breaking during application.

cap and roof tile with opening 250mm

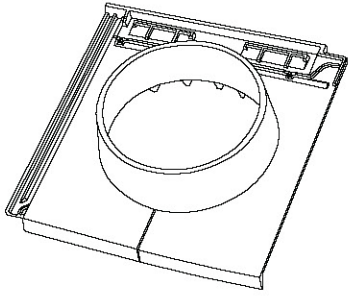

1. Isometric view of roof tile with opening 250mm

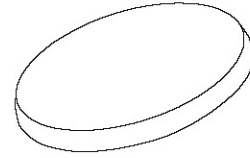

2. Isometric view of cap

Ventilation duct solution

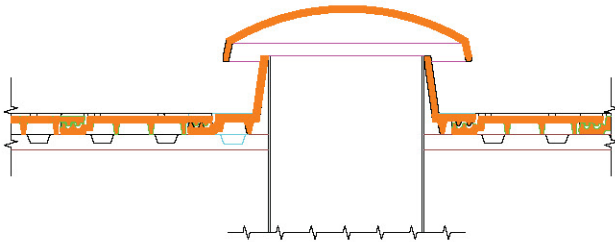

3. Cross-view
4. Longitudinal cut

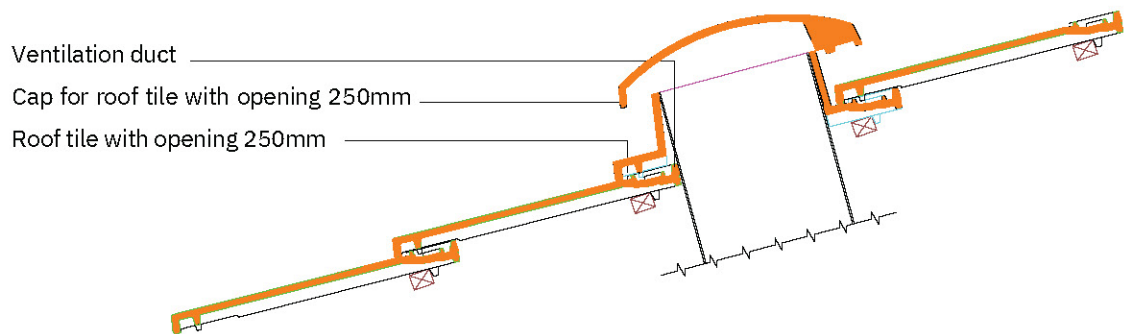

Solar tube solution

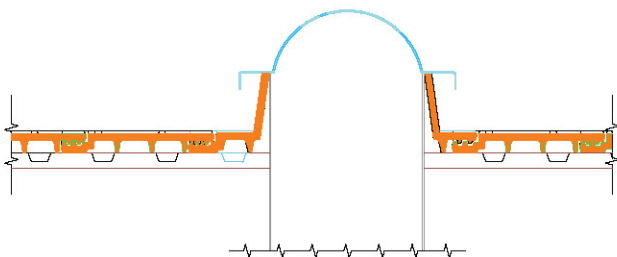

5. Cross-view
6. Longitudinal cut

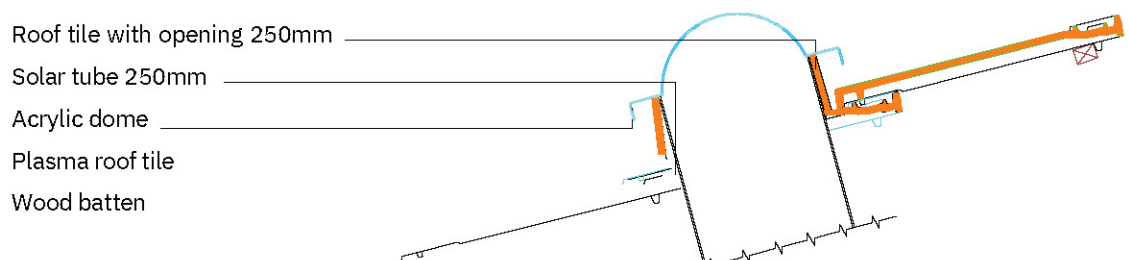

Chimney Flashing

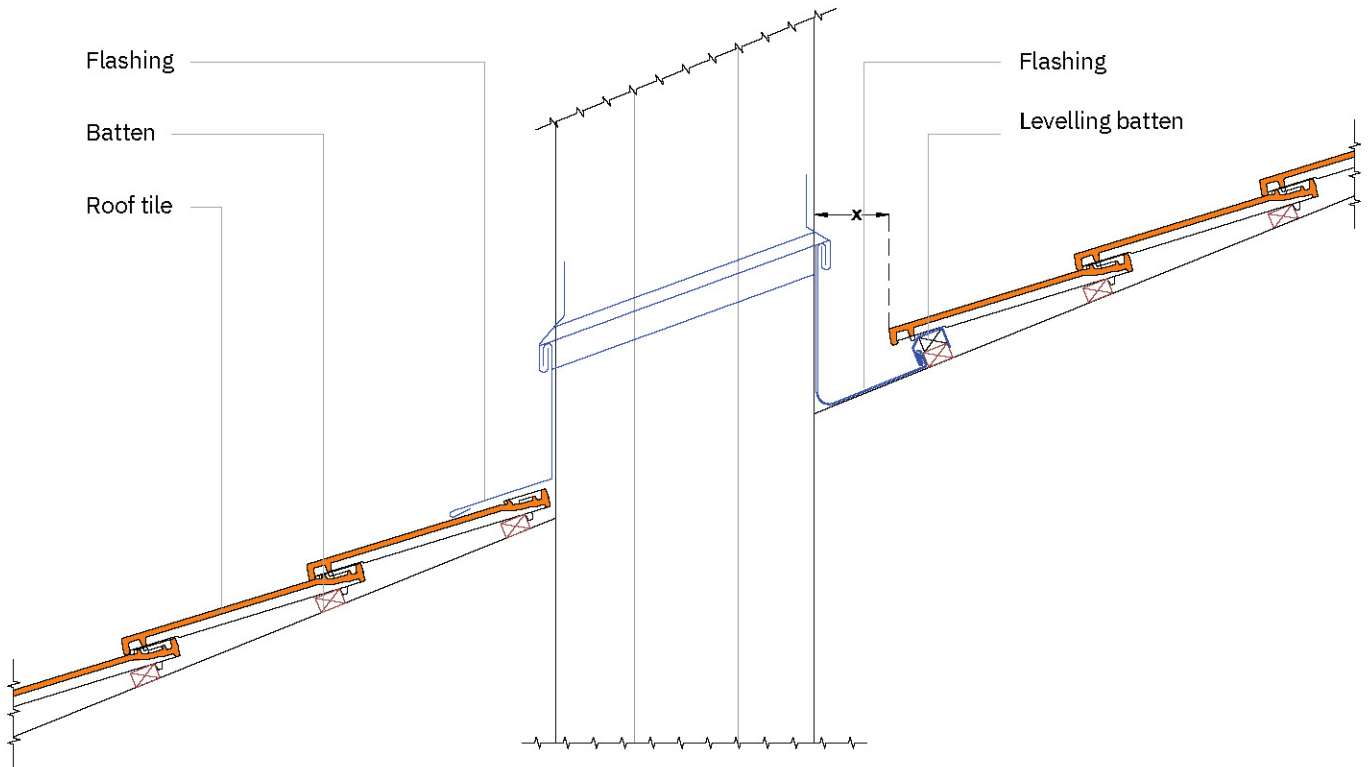

X = Variable measure depending on the length of the sloping plane and the expected amount of water carried on the flashing. However, this measure should be, at least, 150mm.

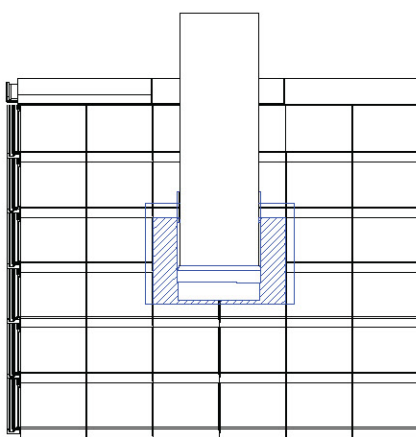

Elevation

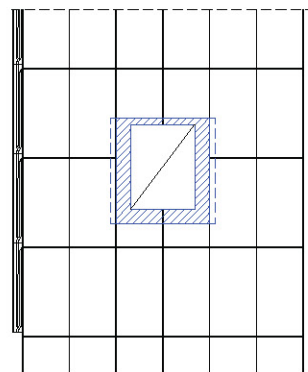

Plan view

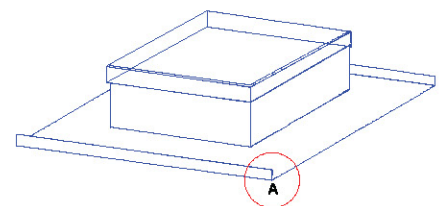

A = It should be created in the casing flange to prevent water from entering the roof. The height of the flange depends on the type of roof structure, and must be at least 20mm (measurement indicative).

Chimney support tile

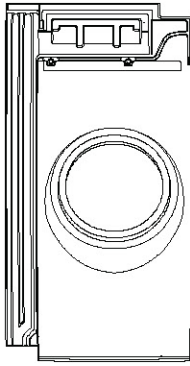

1. Chimney support tile 125mm

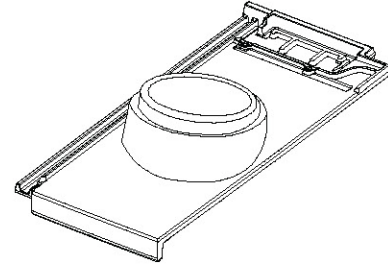

2. Isometric view

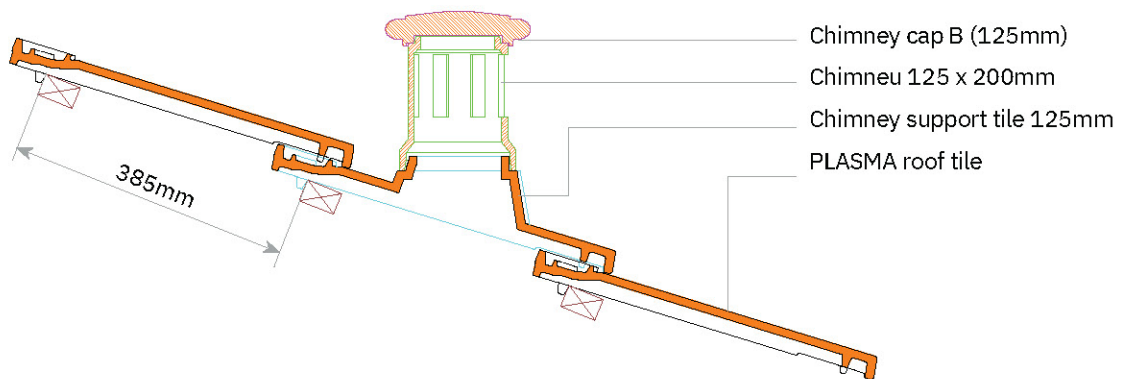

3. Longitudinal cut

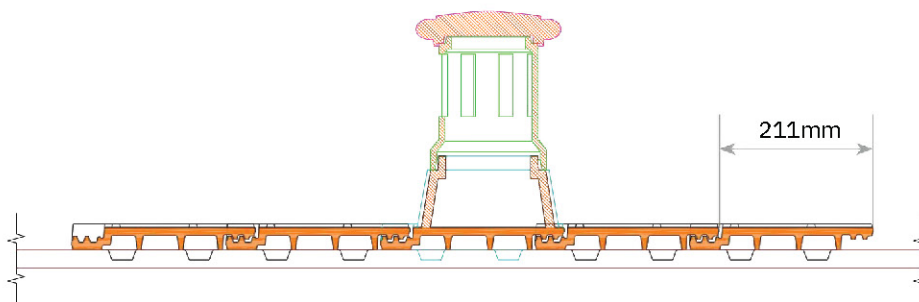

4. Cross-section

Notes:

- Chimney support tile 125mm PLASMA is designed for an average slope of 22°(40%). For other inclinations, the combination of the base with the chimney flue must be adjusted on site.
- The presented measures are approximate values in “mm”. Please consult LOHAS technical department to clarify any doubt.

collector solar module

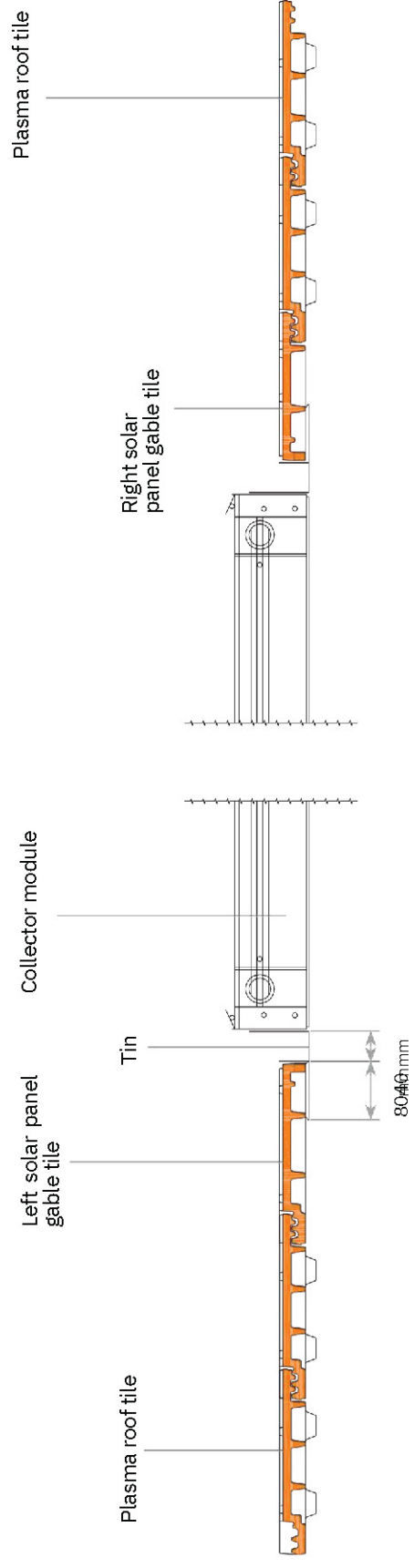

Horizontal cut

eave detail with gutter

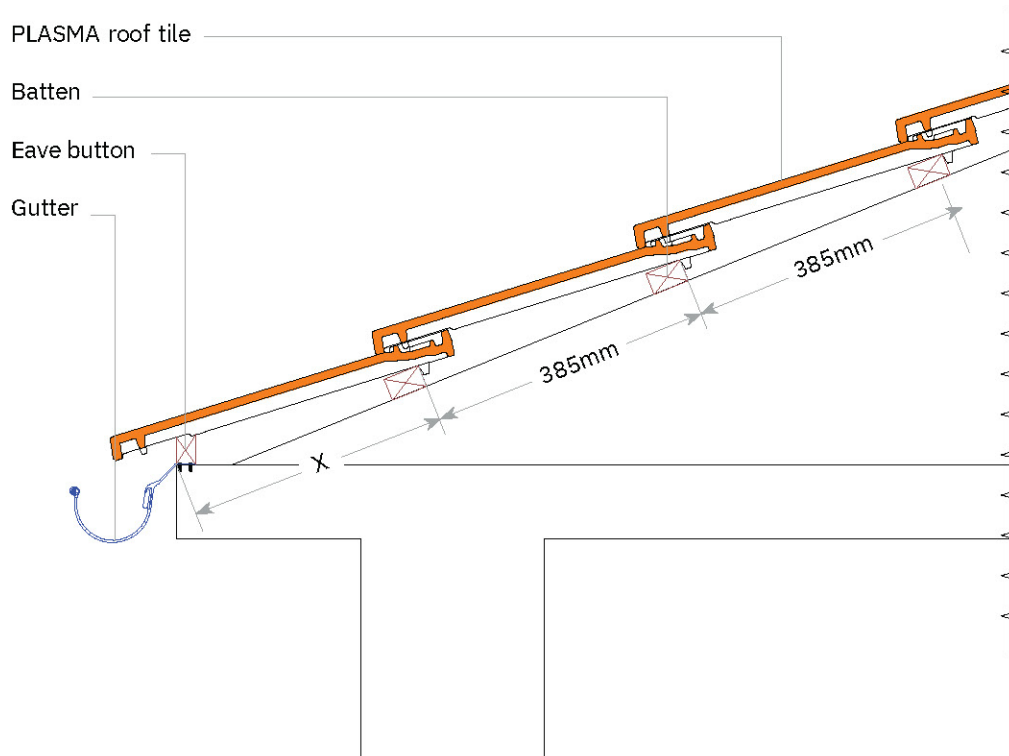

X = Variable measure depending on the roof pitch.

eave detail

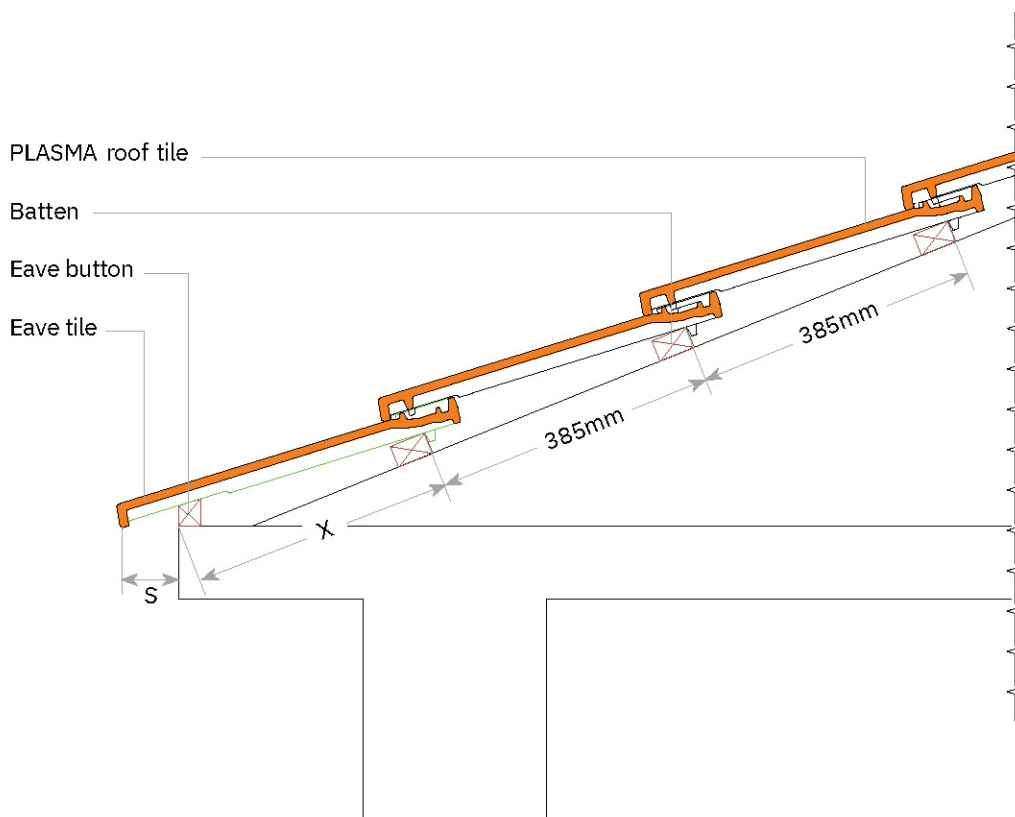

X = Variable measures depending on the roof pitch and measure expected to be projected beyond the wall (S). S = Measure advised to be between 50 e 150mm, for Plasma roof tile.

external facade corner

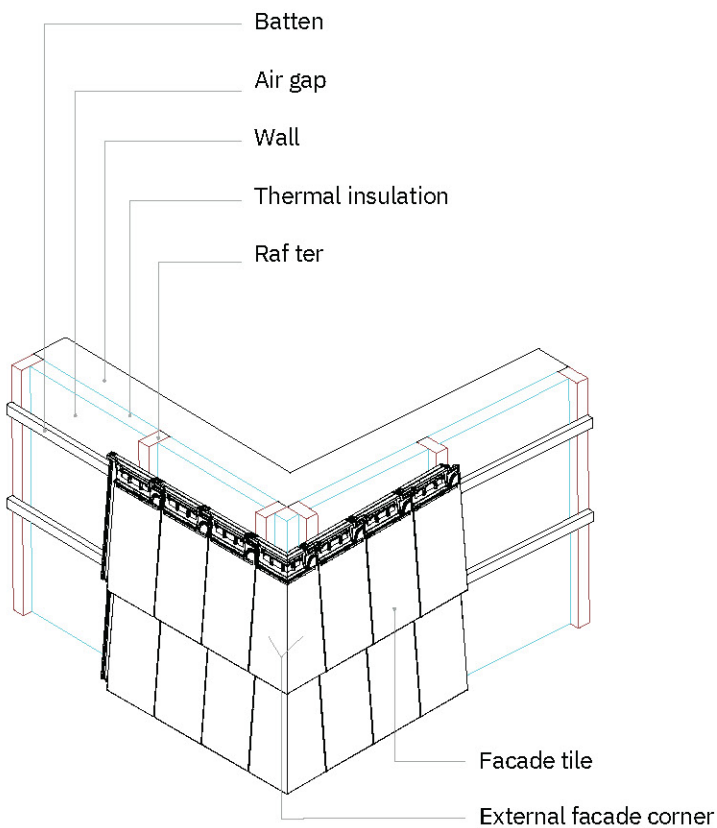
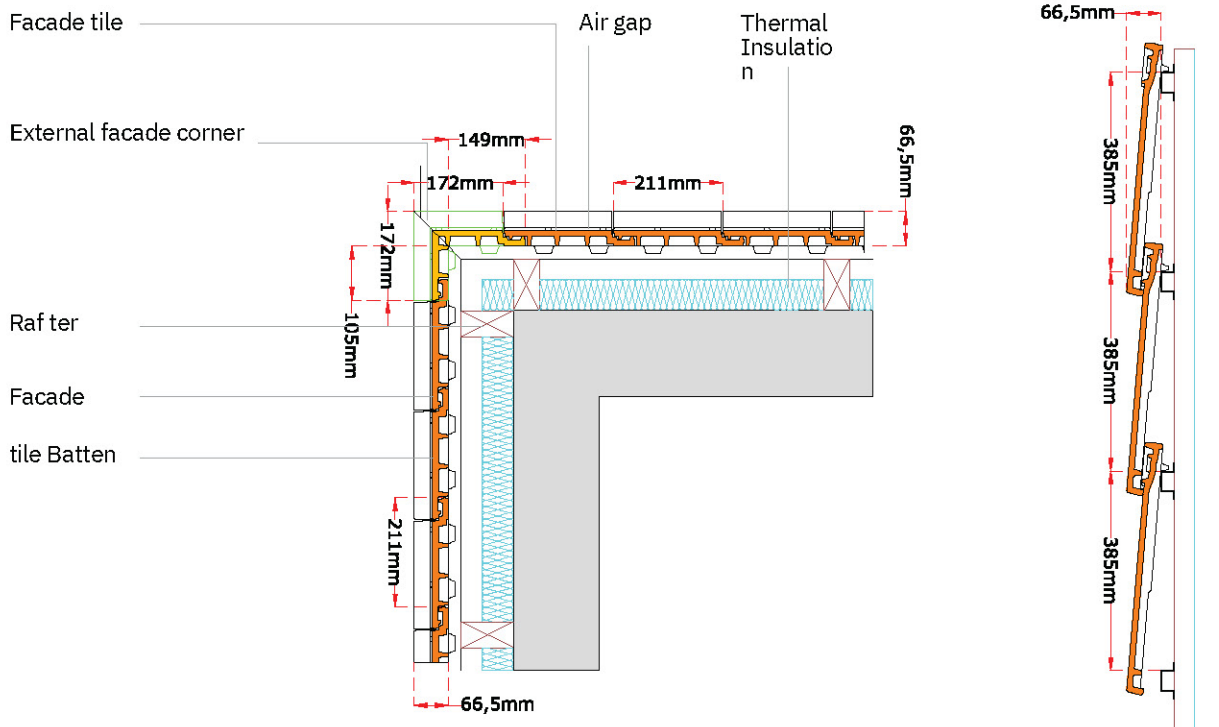

1. External facade corner

The intersection angle of two vertical planes may not necessarily be 90. These fittings can be adapted to different angles (please consult LOHAS Technical Department).

Plasma allows the possibility of simultaneous use on the roof as well as on the facade (there are specific accessories to do this interface). It has two pre-holes so that it can be vertically fixed, with self-drilling screws and washers, our factory also developed an additional metallic "clip" for using one in each tile of the facade.

The use of Plasma roof tile on the facade, should always implicate the previous evaluation and advising from LOHAS technical department, through the analysis of the architecture project.

It is not advisable to fix Plasma roof tile using nails, however, opting for this method the tip of the nail should be adapted to prevent cracking or breaking during application.

2. External facade corner - isometric view

finishing the corner with Barge Tiles

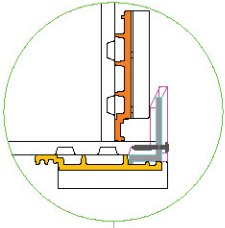

1.Right corner

When applying the barge tile on the corner, the batten should be as much salient as possible, to allow the fixing of the trim strip to the barge, via a screw, placed on top of the gable or on sideways.

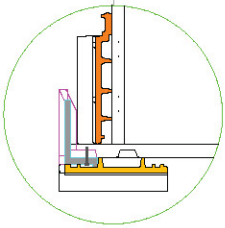

2.Left corner

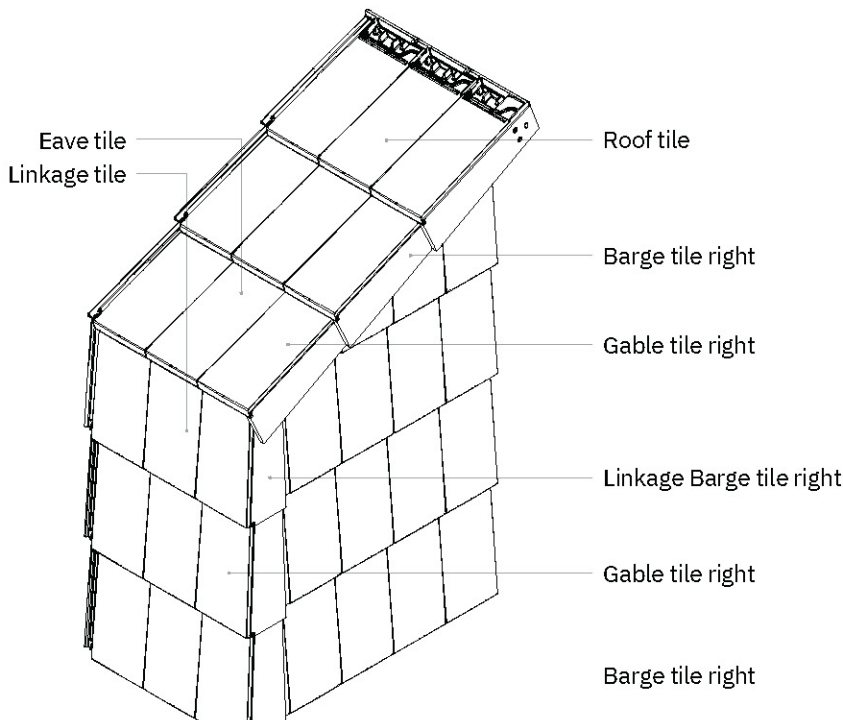
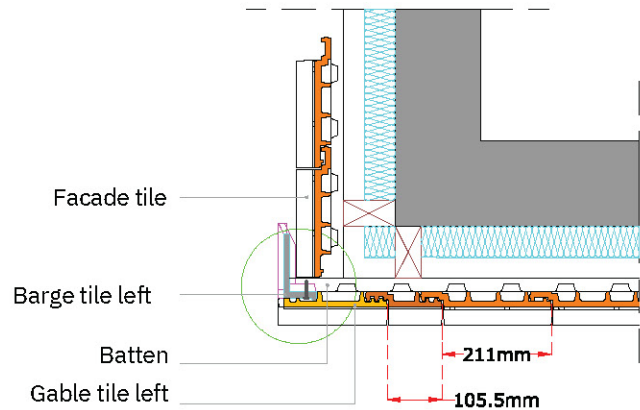
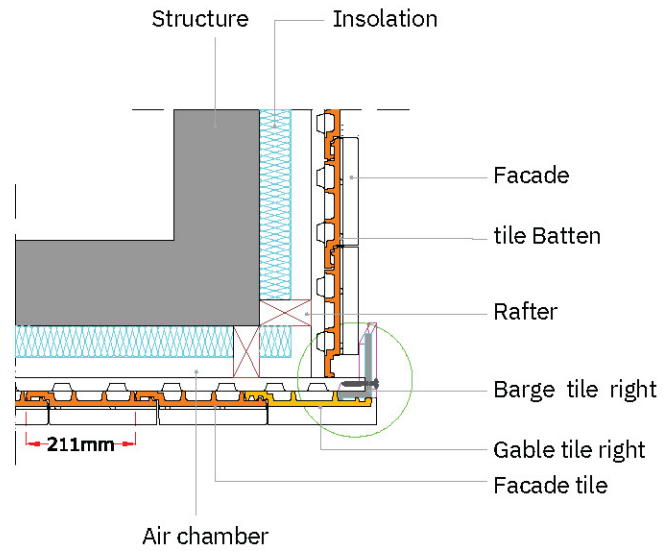

3.Isometric view of the right corner in the facade

Notes:

In areas of high exposure of the roof, the fixing can be achieved by applying screws and washers to pre-existing holes in the roof tiles.

Our factory also developed an additional metallic "clip" for joint application, using one for each tile on the facade. The application of the Plasma roof tile on the facade always involves the preliminary assessment and counseling by LOHAS Technical Department, by providing the elements of architectural design.

finishing the roof edge with/without wall

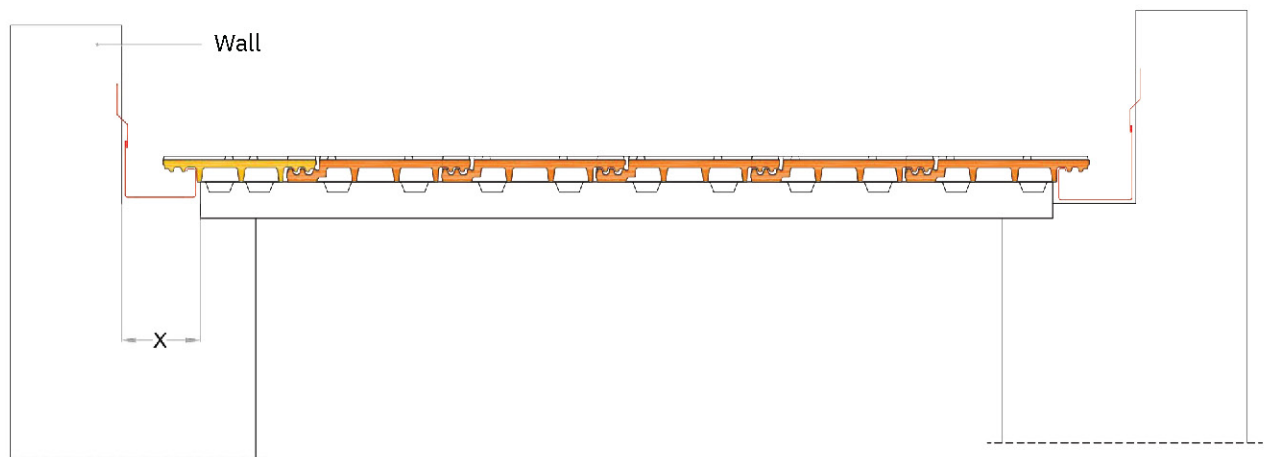
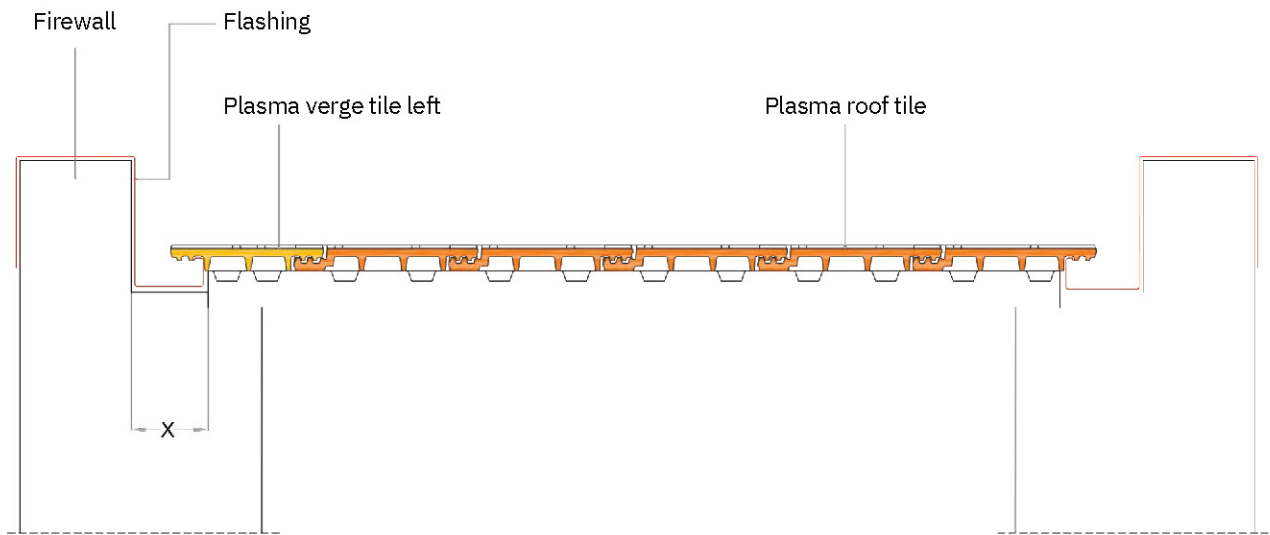

X - Variable measure depending on the length of the sloping plane and the expected amount of water carried on the flashing.

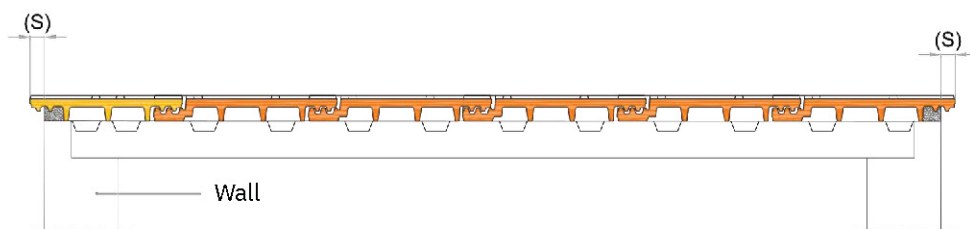

(S) - Plasma roof tile and left verge tile lateral overhang, should be between 15 and 20mm creating a "drip" effect preventing the water flow in the wall. These pieces fixation is made by applying mortar or other similar products of low absorption (eg. FLEXIM). In areas of high exposure of the roof, the fixing can be achieved by the application of screws and washers in the pre-existing holes.

finishing the roof edges with Barge Tiles

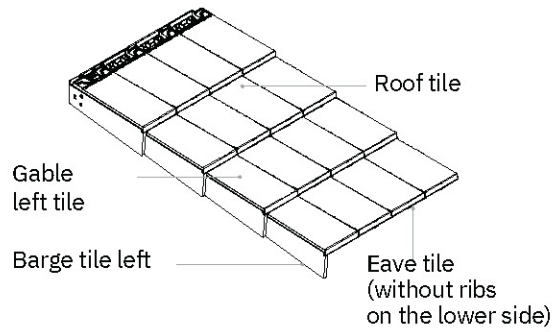

1. Aligned joint. The roof left edge.

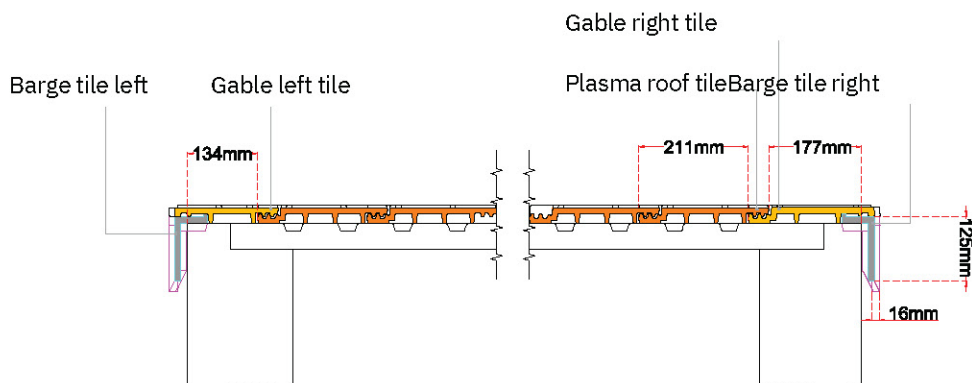

2. Aligned joint. Cross-section.

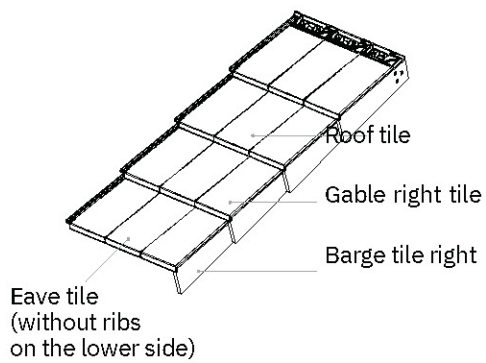

3. Aligned joint.

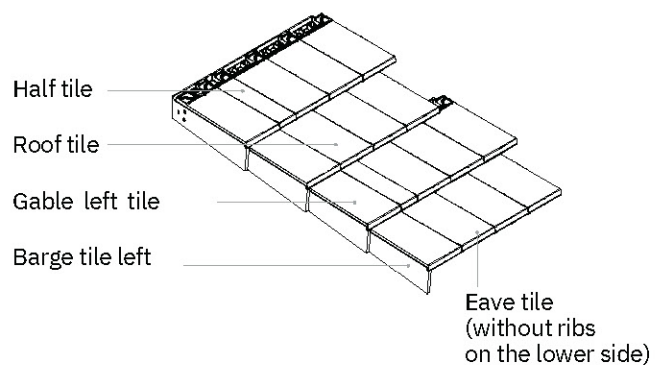

4. Crossed joints. The roof left edge.

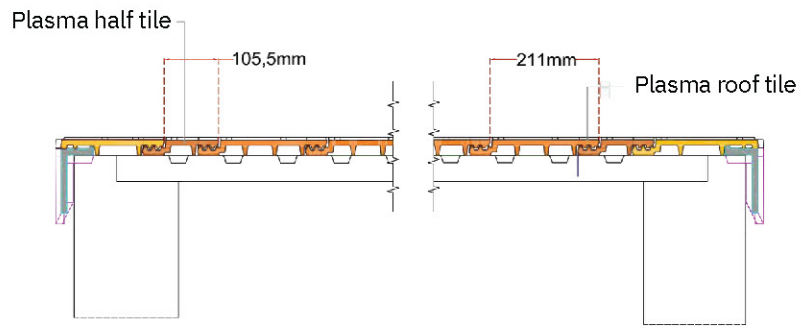

5. Crossed joints. Cross-section

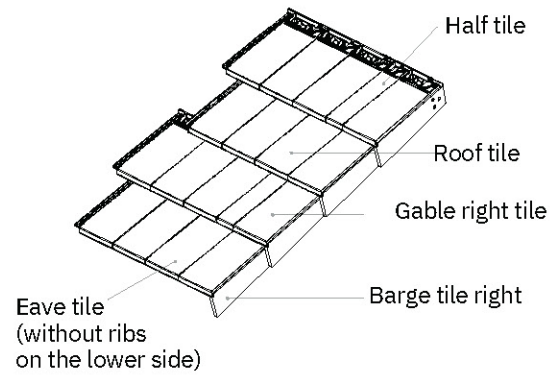

6. Crossed joints. The roof right edge.

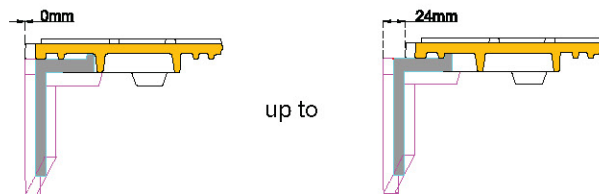

7. Barge tile allowed covering extend.

Note 1 : The presented measures are approximate values in mm.
 Note 2 : The average width of 4 Plasma roof tile is 844mm.

imbedded gutter finish detail

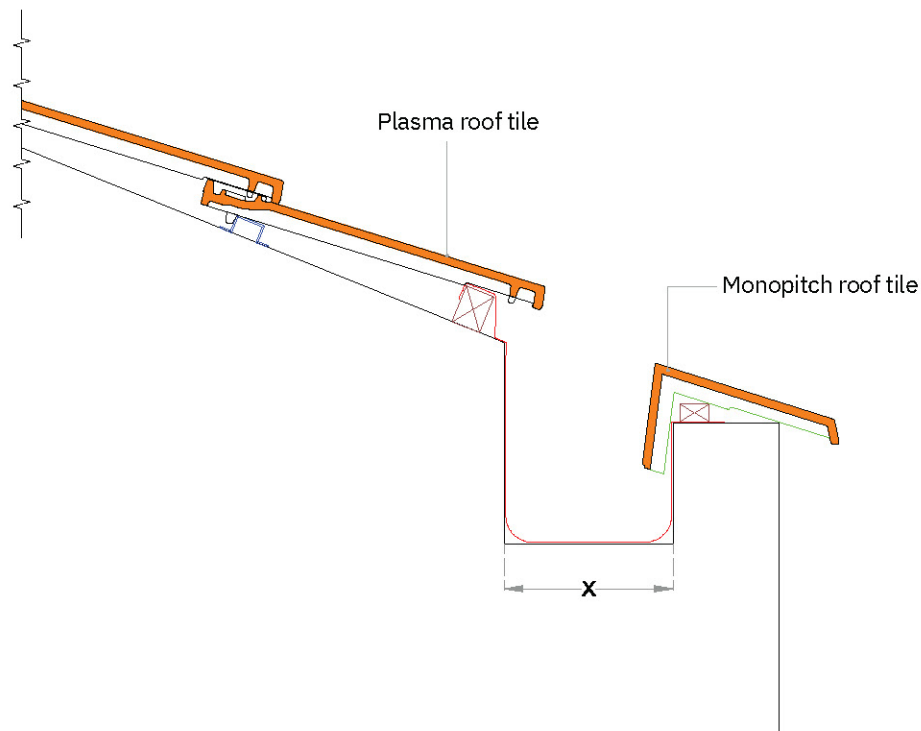
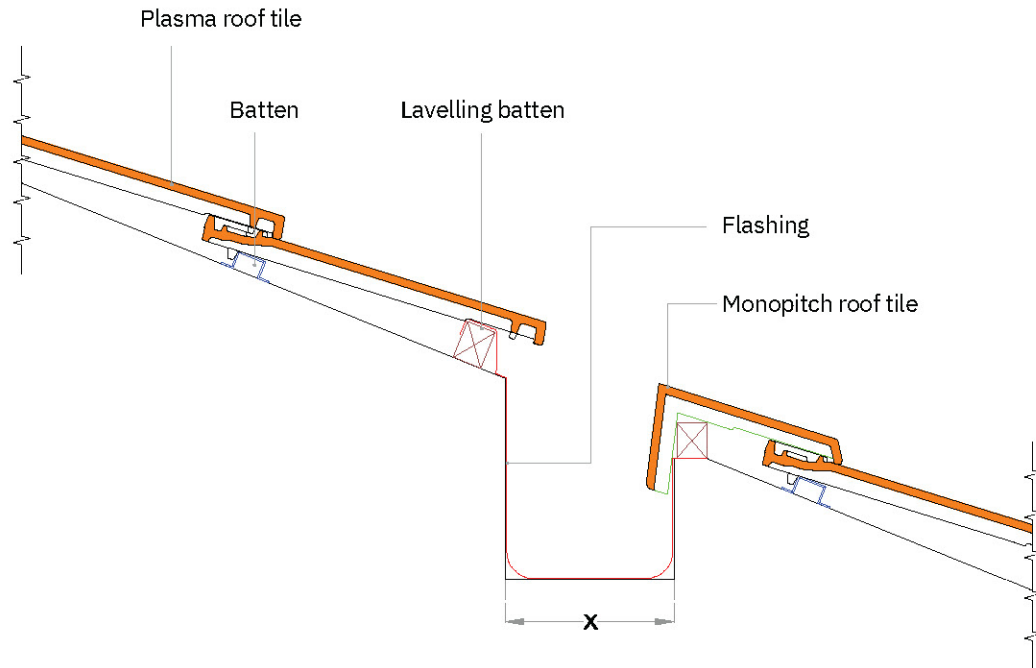

X = Variable measure depending on the length of the sloping plane and the expected amount of water carried on the flashing.

internal facade corner

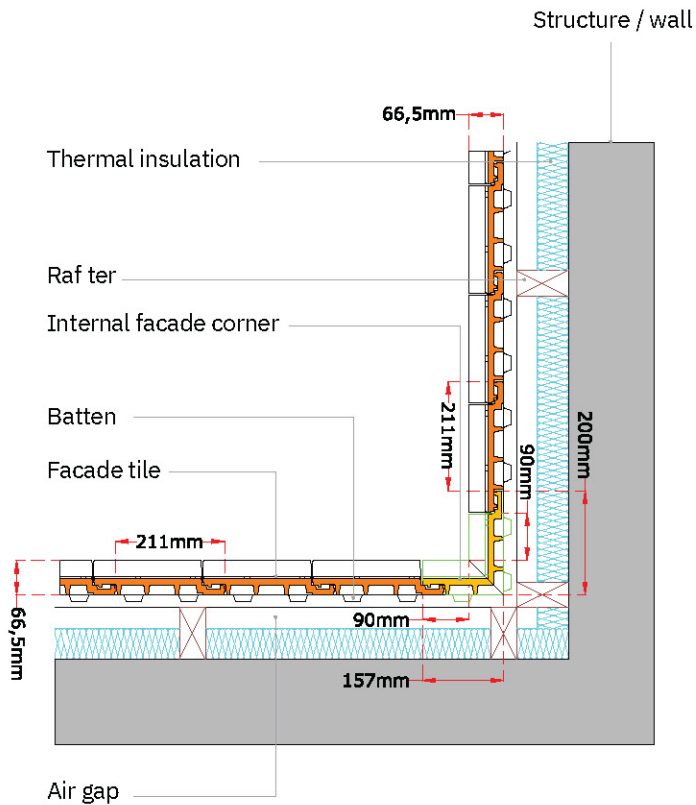

1. Internal facade corner

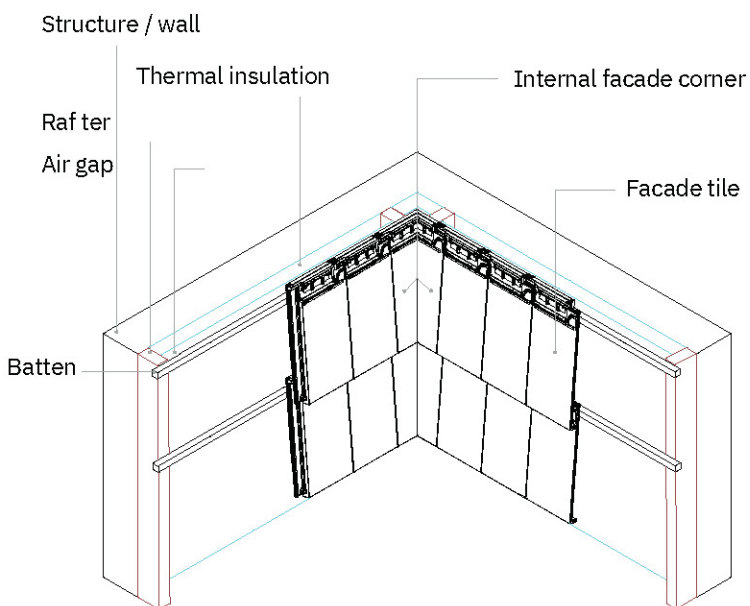
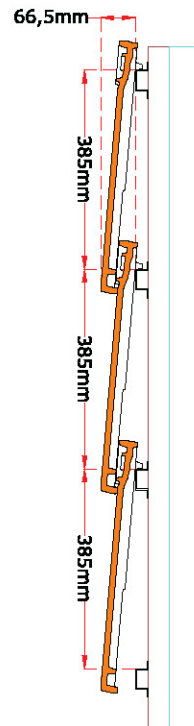

2. Internal facade corner - isometric view

The intersection angle of two vertical planes may not necessarily be 90°. These fittings can be adapted to different angles (please consult LOHAS Technical Department).

Plasma allows the possibility of simultaneous use on the roof as well as on the facade (there are specific accessories to do this interface). It has two pre-holes so that it can be vertically fixed, with self-drilling screws and washers, our factory also developed an additional metallic "clip" for using one in each tile of the facade.

The use of Plasma roof tile on the facade, should always implicate the previous evaluation and advising from LOHAS technical department, through the analysis of the architecture project.

It is not advisable to fix Plasma roof tile using nails, however, opting for this method the tip of the nail should be adapted to prevent cracking or breaking during application.

mansard tile detail

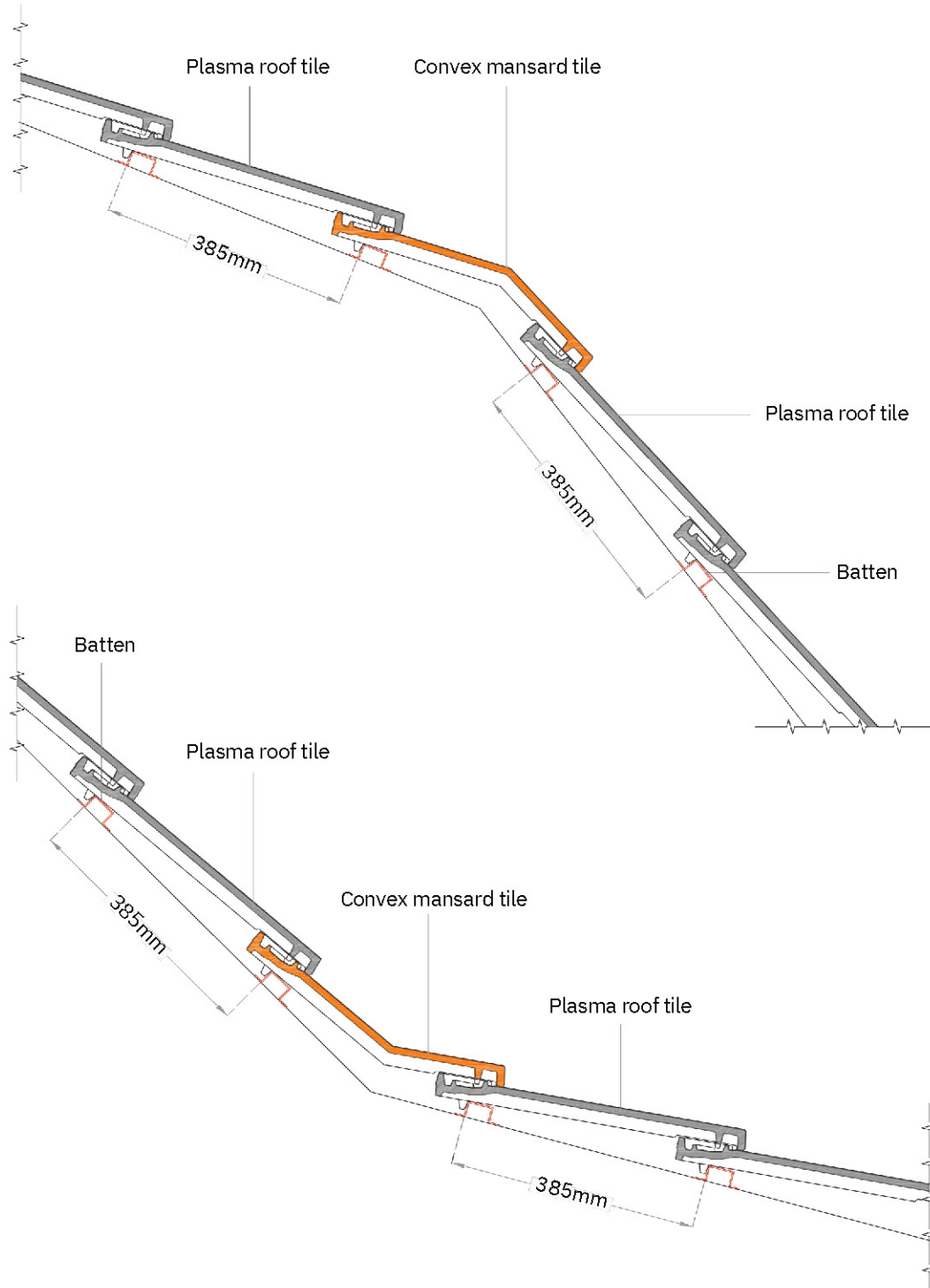

Notes:

- Pieces available in various angles.
- The presented measures should be considered approximate. More questions, please contact the LOHAS Technical dept.

monopitch roof detail

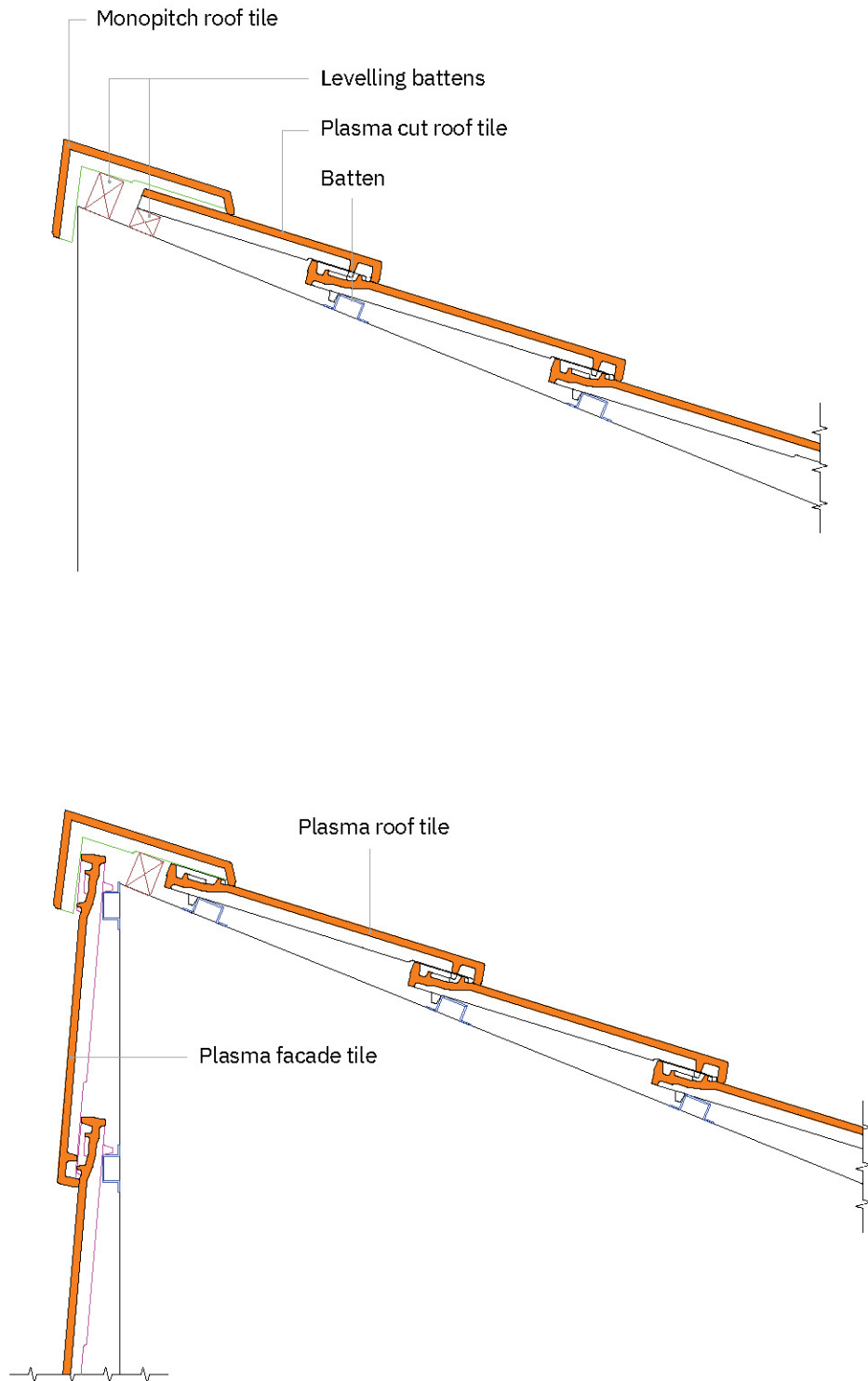

potovoltaic solar module

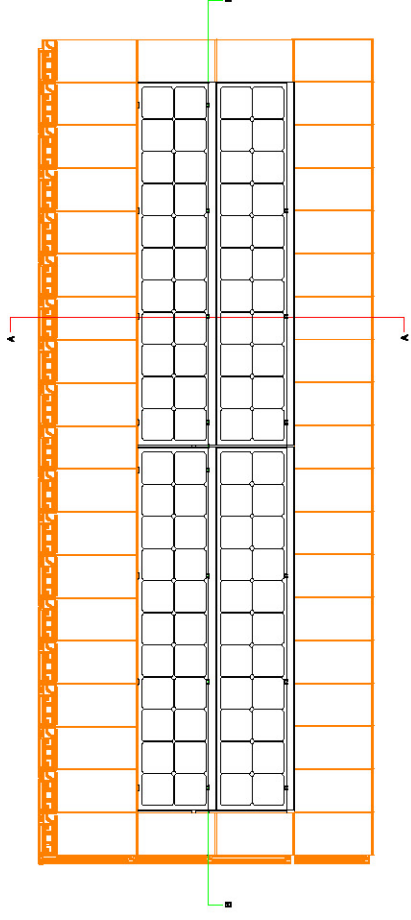
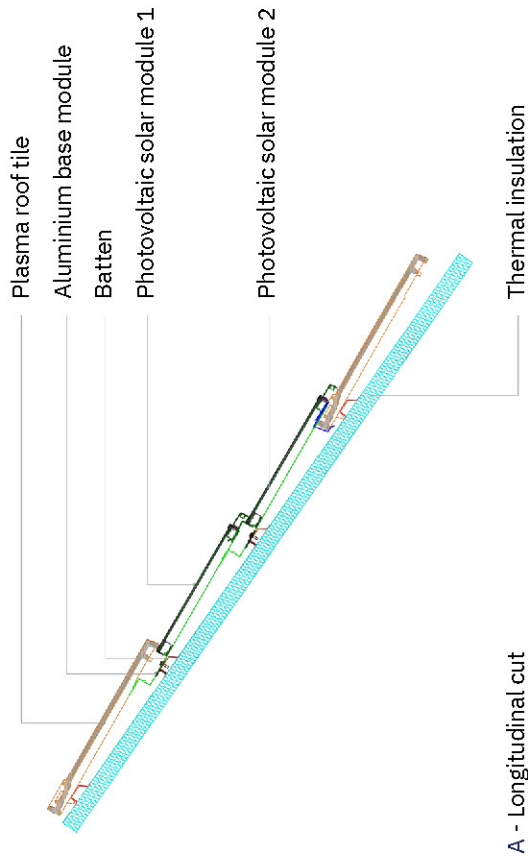

1. Plan view (4 PV modules application)

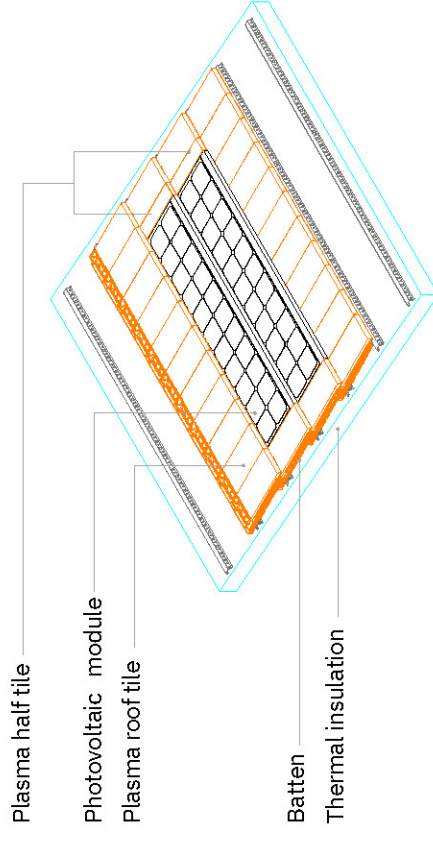

2. Isometric view (2 PV modules application)

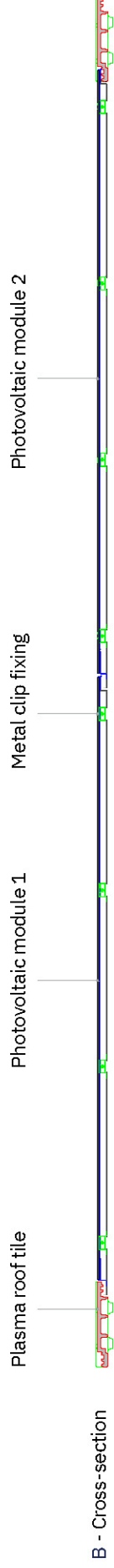

ridge tile detail

application with mortar

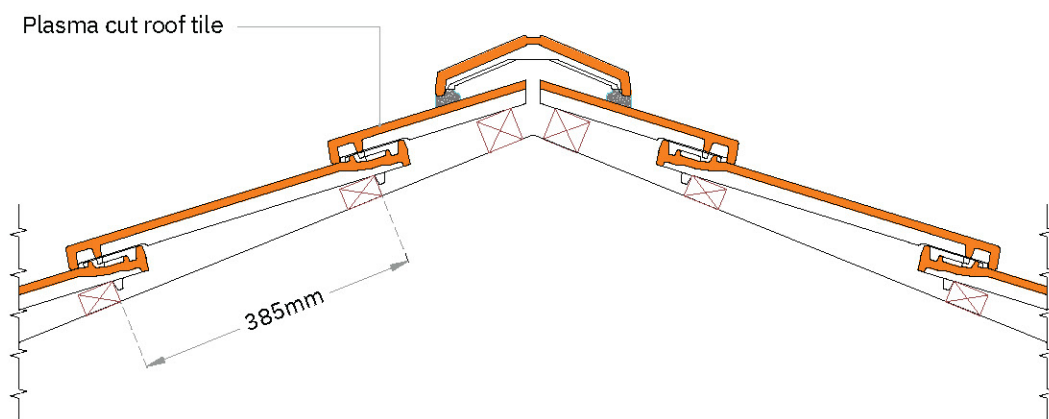
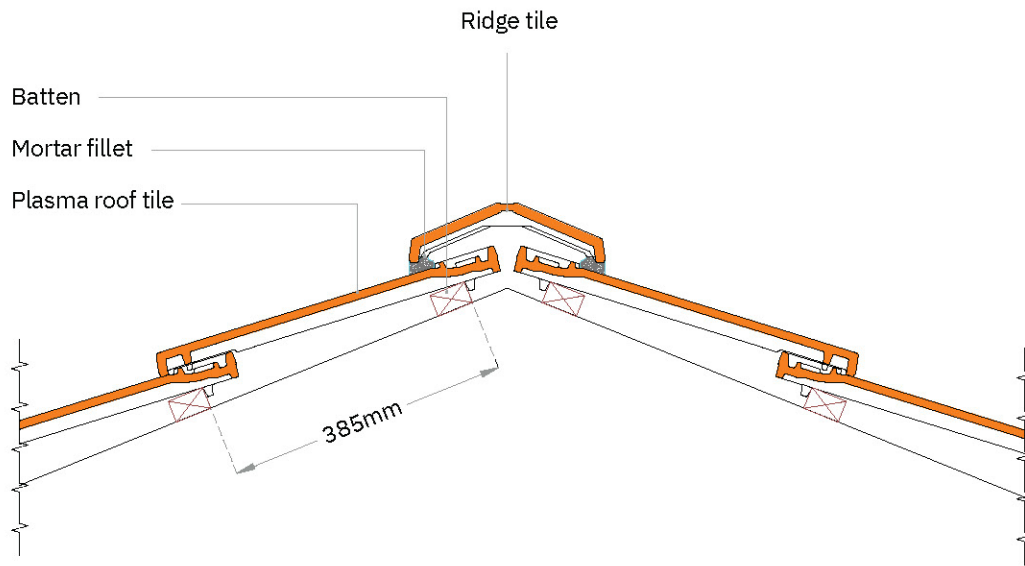

ridge tile detail

Dry application

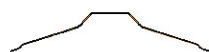
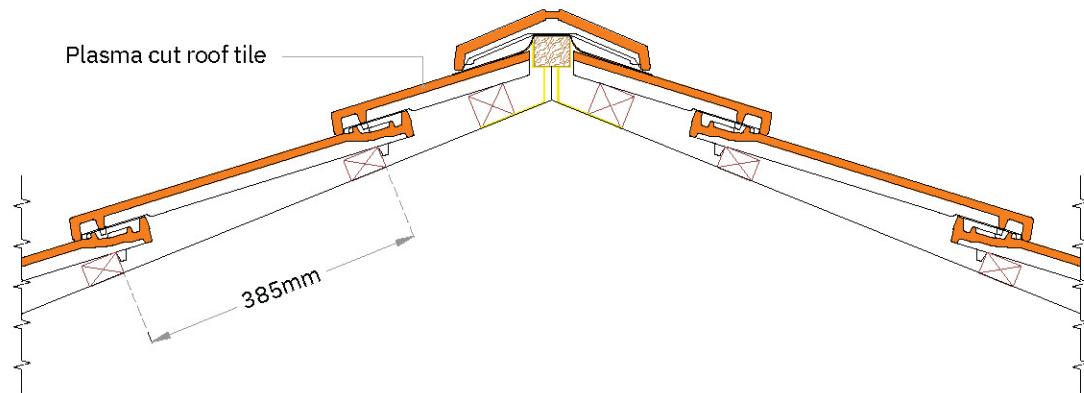
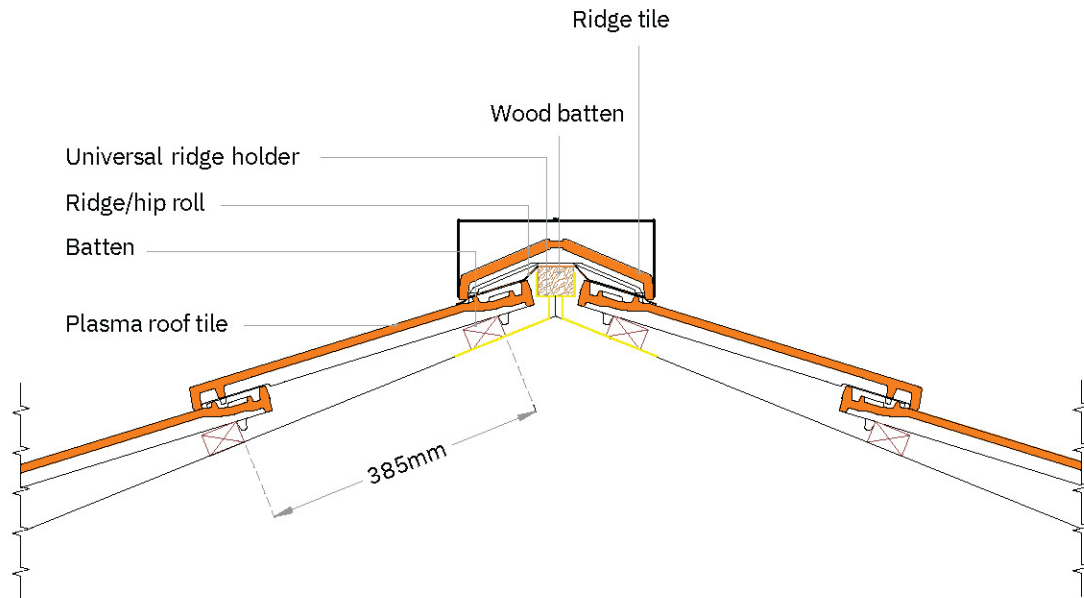

Roll to use on ridges and hips.

Lohas PLASMA Aluminium Profiles

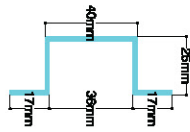

Omega aluminium profile

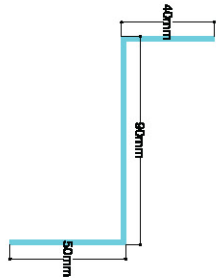

"Z" Aluminium profile

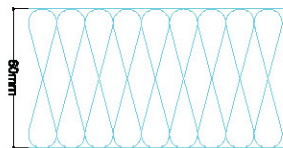

Thermal insulation
(expanded polystyrene - plates with
1000 x 1000 x 60mm)

Omega aluminium profile

Plasma facade tile

Thermal insulation
Wall

Fixing clip (10mm)

"Z" aluminium profile

self-drilling screw
4.8mm x 50mm

sealing washer (16mm)

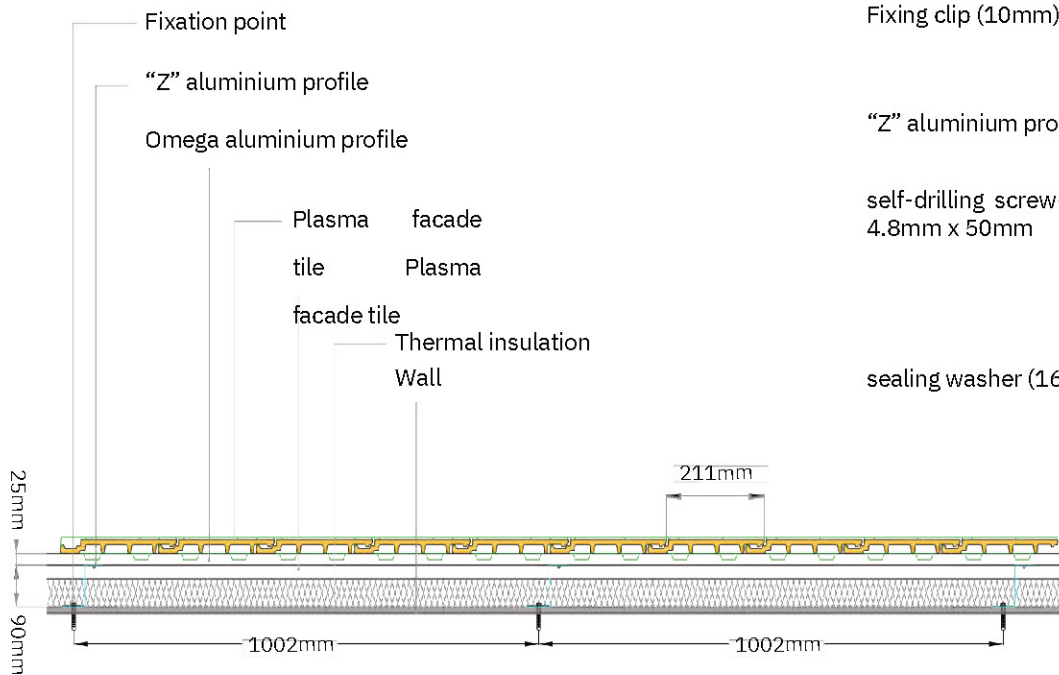

Fixation point

RIDGE DETAIL

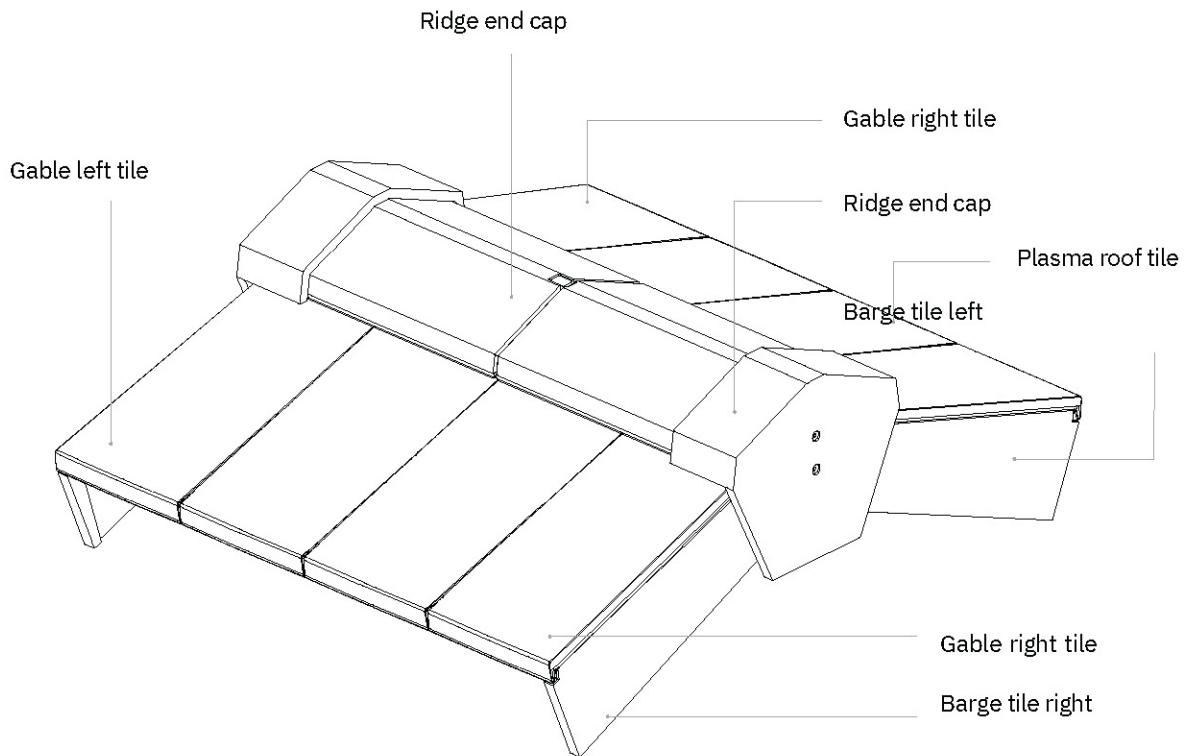
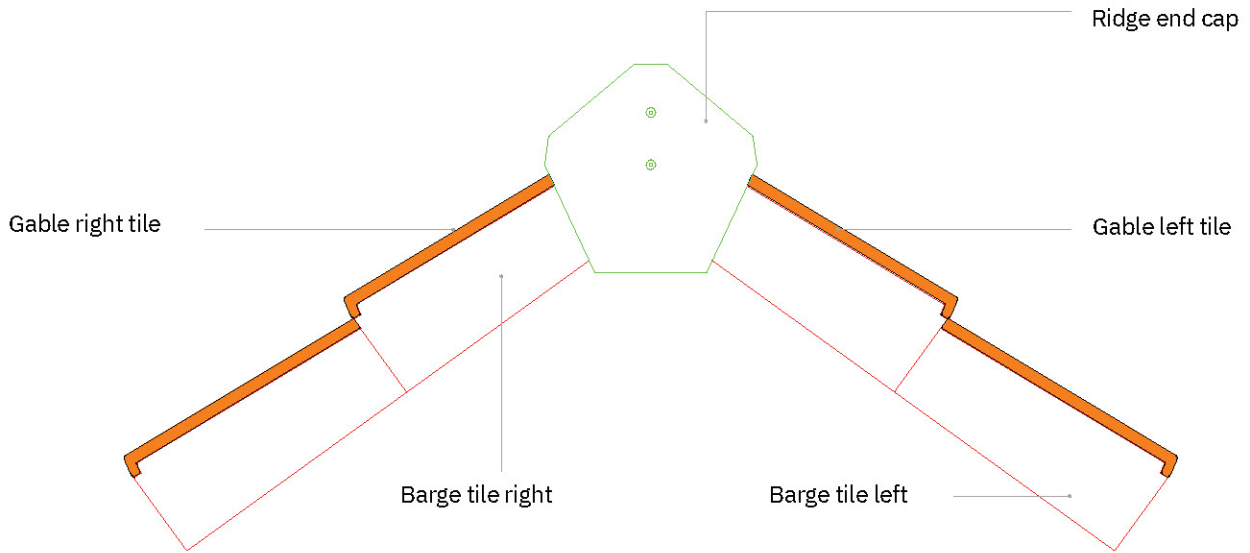

special finishing situations

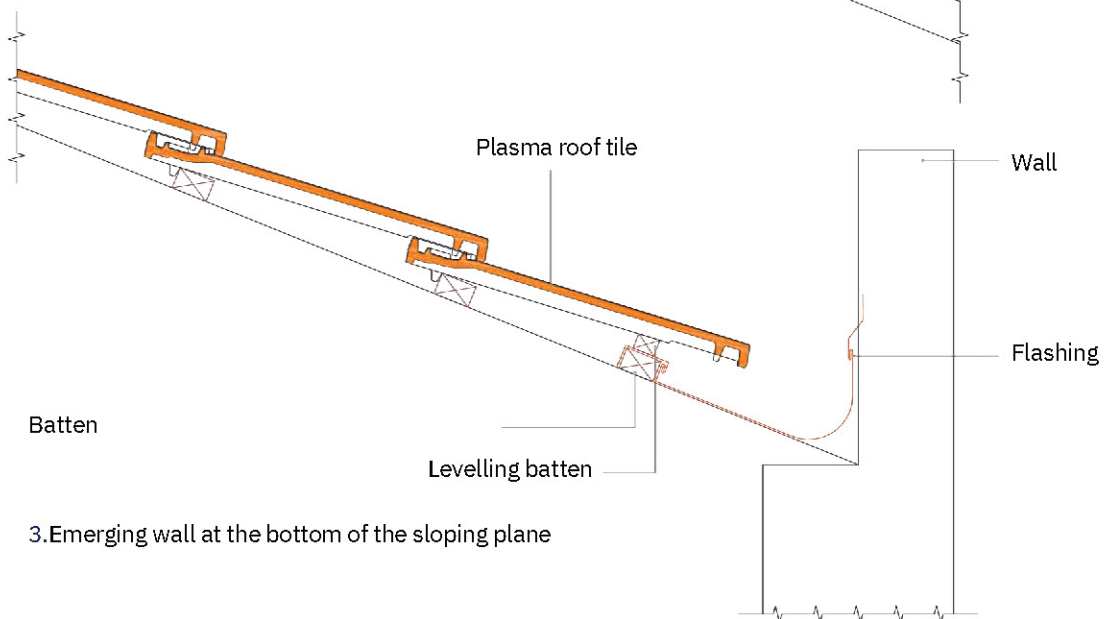
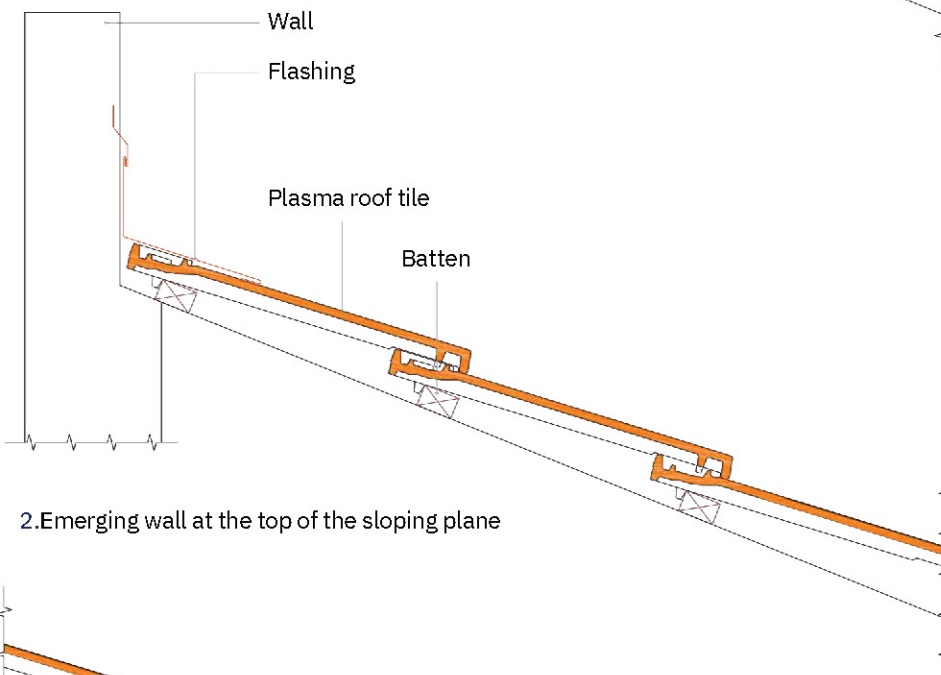
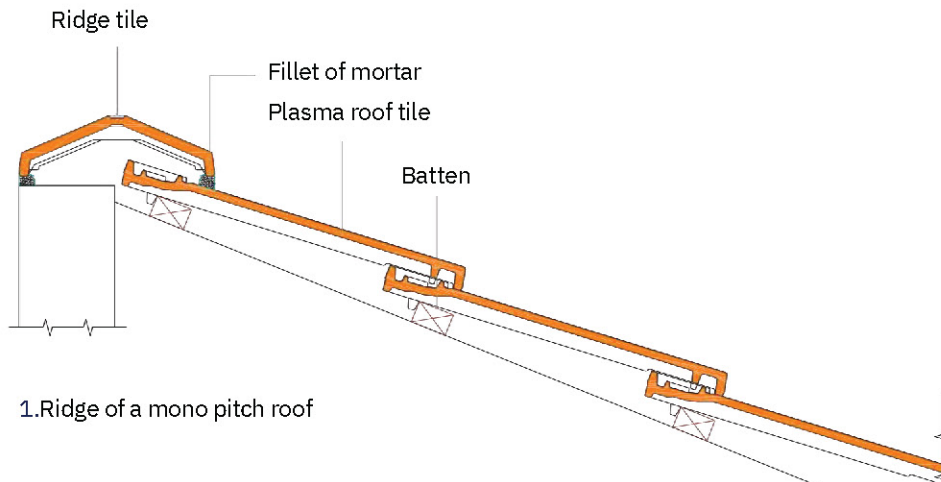

valley detail

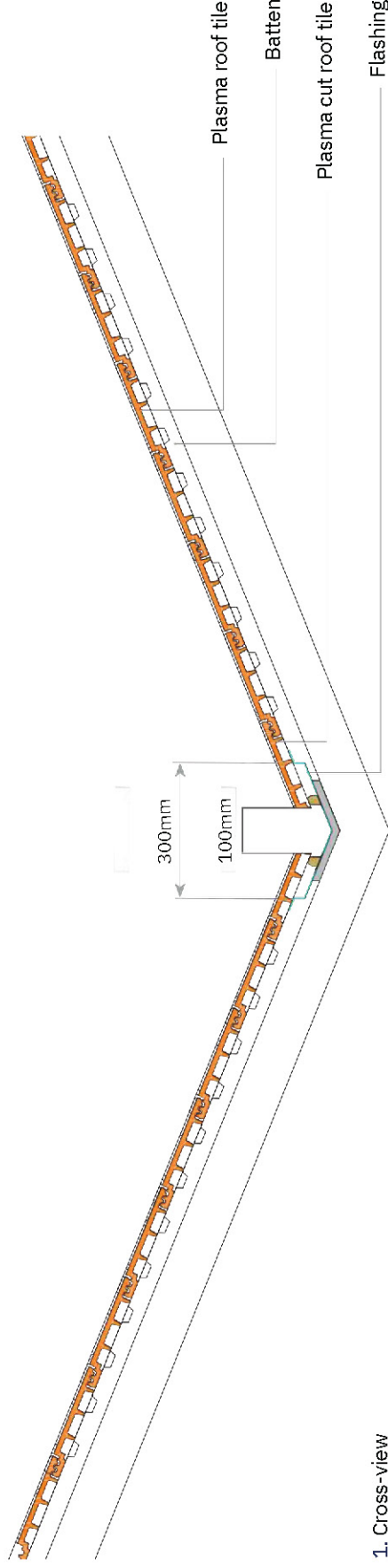

1. Cross-view

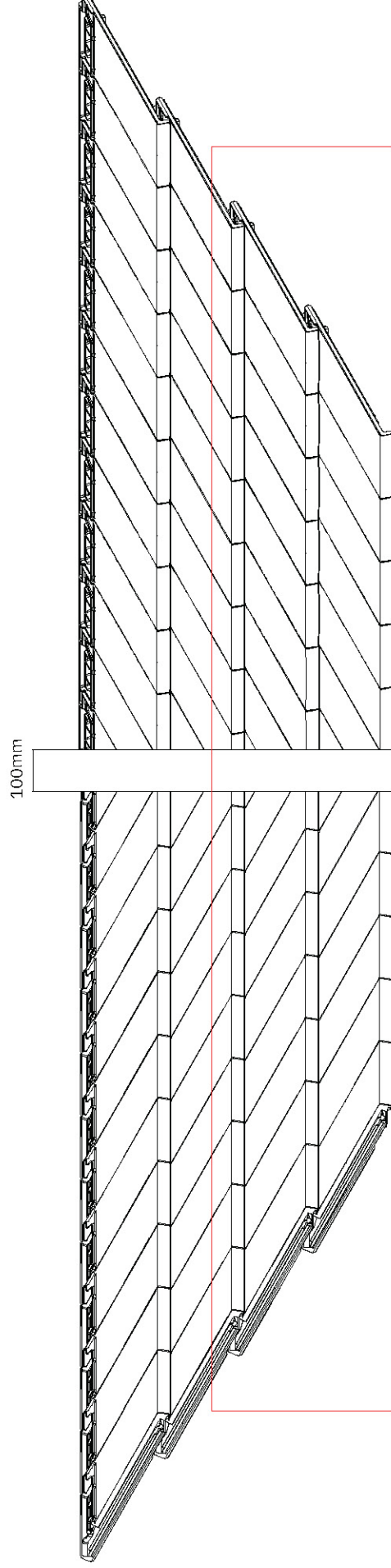

2. Isometric view

wall roof linkage

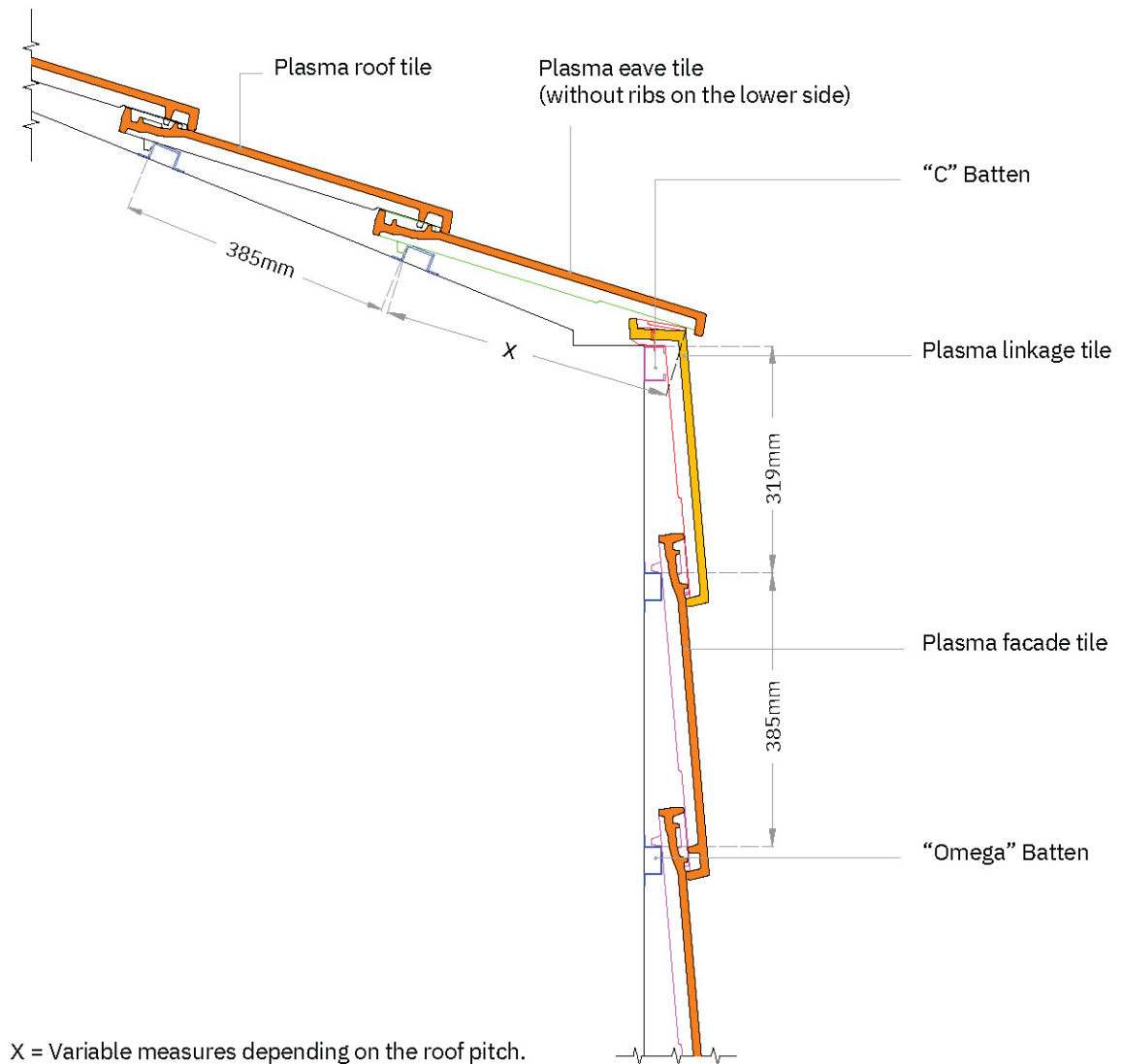

Notes:

Plasma allows the possibility of simultaneous use on the roof as well as on the facade (there are specific accessories to do this interface). It has two pre-holes so that it can be vertically fixed, with self-drilling screws and washers, LOHAS also developed an additional metallic "clip" for using one in each tile of the facade. The use of Plasma roof tile on the facade, should always implicate the previous evaluation and advising from LOHAS technical department, through the analysis of the architecture project. It is not advisable to fix Plasma roof tile using nails, however, opting for this method the tip of the nail should be adapted to prevent cracking or breaking during application.

SLATE

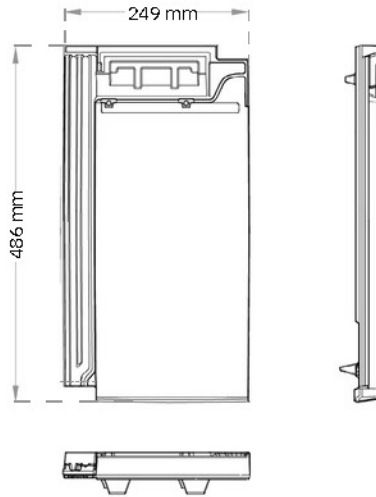
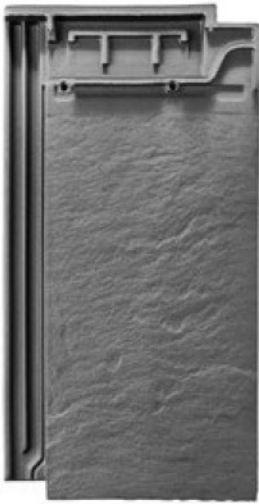

12.5 Tiles/sqm

6 Tiles per pack

4 kg Weight

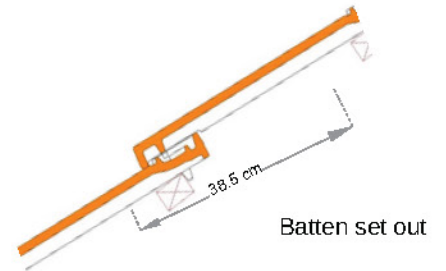

Flexural Strength

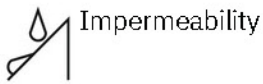

Impermeability



Frost Resistance

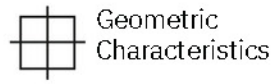

Geometric Characteristics



Roofing & Facade

Colours



TX5 Anthracite

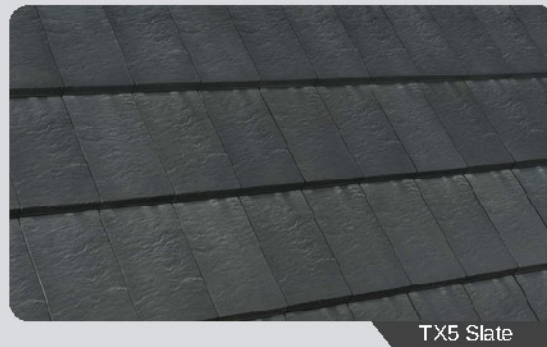

TX5 Slate

GARANTIA WARRANTY
50
ANOS . YEARS

Accessories



RIDGE



STARTER



3-WAY APEX



HALF TILE



BARGE

Inspired by the schist villages, LOHAS Slate roof tile seeks to reflect an ancient roof covering concept by reproducing the texture of slate in clay tiles. Developed exclusively for roof coverings, LOHAS Slate keeps the quality and all functional properties of Plasma roof tiles. To ensure an irregular pattern, two different textures have been designed, pressed and packed together so the roof schist appearance looks natural.

LOHAS

CONTACT US

P 02 9566 2114
E info@lohasau.com

W lohasau.com
IG [@lohas_australia](https://www.instagram.com/lohas_australia)

LOHAS Australia is a proud distributor of the CS product range.

